

Grant of a patent is requested on the basis of new claims 1 to 4, original description pages 2, 6, 7 and 9, amended description pages 1, 4, 5, 8 and 10 to 12 as filed with our letter of November 30, 2006, new description page 3, original pages 1/4, 3/4 and 4/4 of the drawings and new page 2/4 of the drawings.

Auxiliary, oral proceedings are requested should the Examining Division have any hesitations to grant a patent on the basis of the attached claims.

Editorial amendments can be discussed by phone.

  
D. Finck

Enclosures

- new claims 1 to 4
- amended description page 3
- amended page 2/4 of the drawings

AN/sk

**CLAIMS**

1. A locking connector (21, 22) for a suspended ceiling grid comprising a main beam (20) and cross beams (26, 27),
  - wherein the locking connector (21) is designed to be stabbed through a slot (23) in the main beam (20) to lock with an opposing identical locking connector (22) already in the slot (23) and has a cantilevered locking latch (40) being integral with and pivoted from a base (41) in the locking connector (21), and
  - wherein, when the locking connector (21, 22) is stabbed through the slot (23) in the main beam (20), the locking latch (40) can be forced by a side of the slot (23) to flex toward the base (41) to permit the locking latch (40) to pass through the slot (23), and when the locking connector (21, 22) has been stabbed through the slot (23), the locking latch (40) can flex back to its relaxed position wherein it is pivoted away from the base (41),characterized in that the locking latch (40) is formed with a curved portion before extending in straight lever fashion.
2. The locking connector according to claim 1, characterized in that the curved portion forms a radius of about 0.1 cm (0.04 inches).
3. The locking connector according to claim 1, characterized in that the locking latch (40) has a straight portion (43) which forms an angle of about 42° with the base (41).
4. The locking connector according to claim 1, characterized in that a delay in contact between the side of the slot (23) and the locking latch (40) is provided when the locking connector (21, 22) is stabbed through the slot (23).

depressed as it passes into the slot to achieve such horizontal alignment. Hence, the profile of the leading edge of the connector is tapered to guide the connector during its travel through the main beam slot.

*of the generic kind* *in U.S. 5,839,246 or U.S. 4,317,641.*

Such connectors are ~~[well known in the prior art and are]~~ disclosed, for instance, *↓*  
~~[in the above referred to patents]~~ *This prior art refers to a locking connector for a suspended ceiling grid as described in the preamble of claim 1.*  
~~[Numerous such connections must be made to create a ceiling grid.]~~

#### SUMMARY OF THE PRESENT INVENTION

*The object of the present invention is to provide a locking connector*

~~[The prior art stab-in connector described above is improved so]~~ that ~~[it]~~ takes much less force, and less work, to make the connection.

There is less work and less force necessary, because, in inserting the second connector into the reduced area of the slot of the main beam, (1) there is a delay in the contact between the locking latch and the side of the slot, so that during the delay, (2) elements in the ensuing connection are positioned while offering the least resistance from frictional forces to such positioning, and (3) when contact between elements does occur, the elements are positioned to offer the least resistance to making a connection.

To achieve the above, the locking latch, which in its unflexed position, must extend laterally far enough out from the base of the connector to prevent withdrawal of the first connector through the slot before the second connector is inserted, ~~[is pivoted from the connector base in an arc, rather than in an acute bend as in the prior art]~~ *is formed with a curved portion before extending in straight lever fashion.*

This, as set forth in (1) above, delays contact between the latch and the side of the slot, when the second connector is inserted into the slot and, as set forth in (2) above, such contact is made further out along the latch from the pivot point, closer to the end of the latch, creating a longer lever arm, so that less force is needed to close the latch.

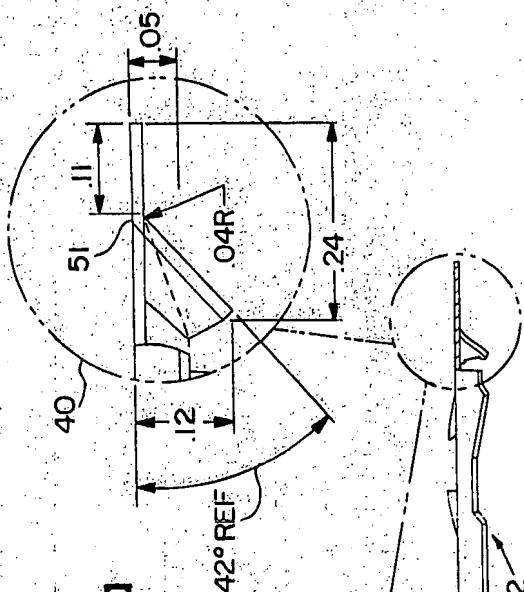

FIG. 2a

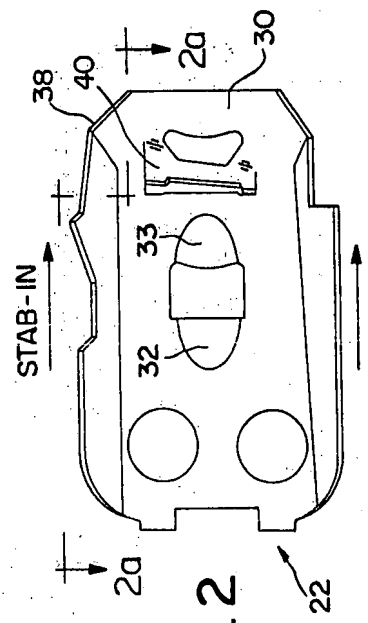
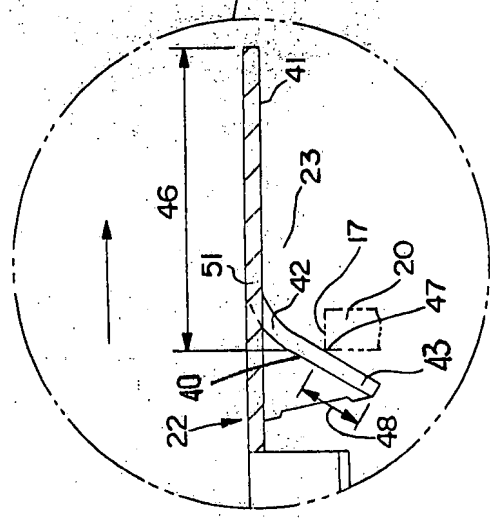

FIG. 2